

Turmdrehkran

32 TTR

Tower Crane / Grue à tour / Gru a torre / Grúa torre
 Guindaste de torre / Башенный поворотный кран

30 - 57 mt

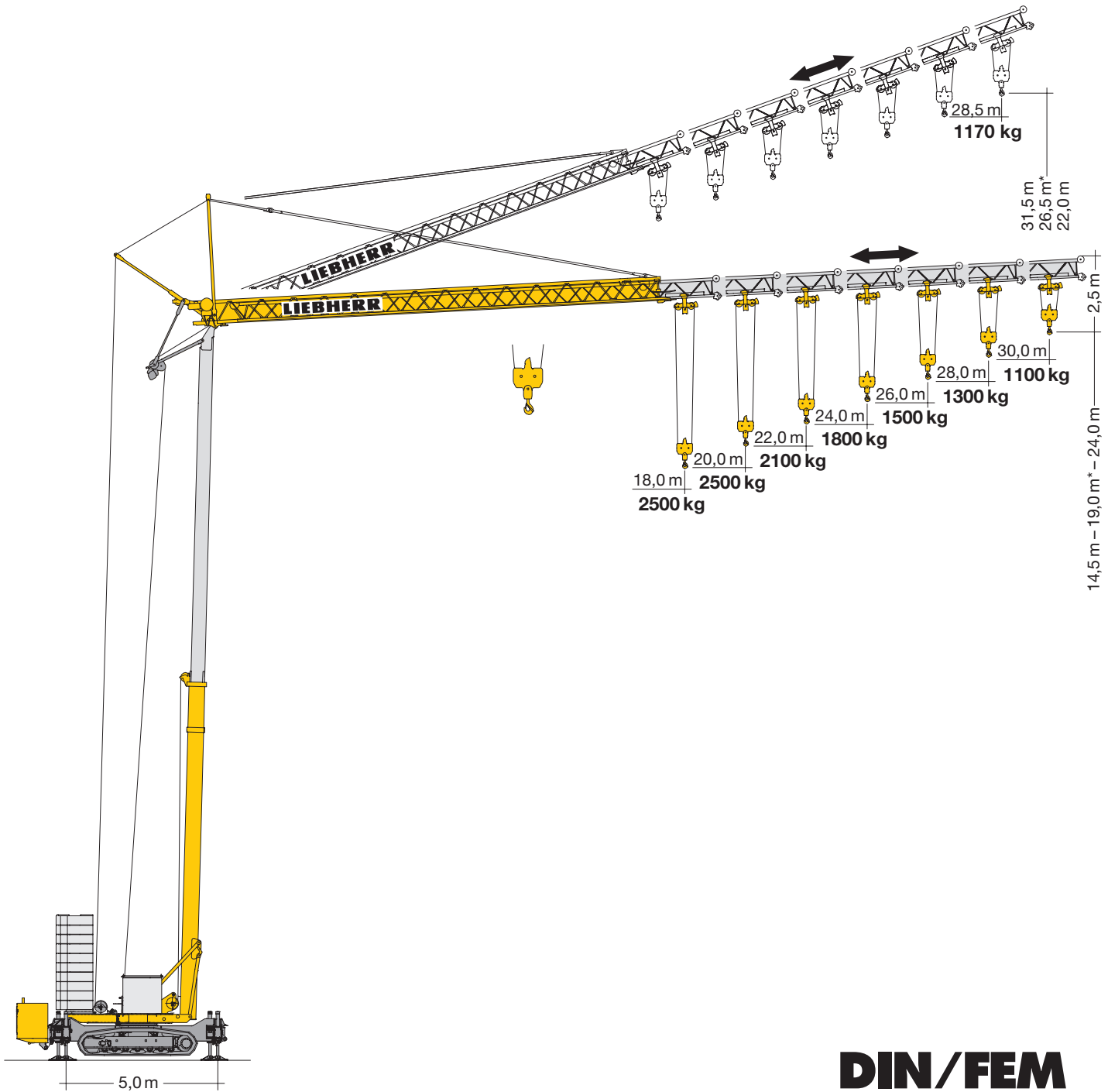

DIN/FEM

LIEBHERR

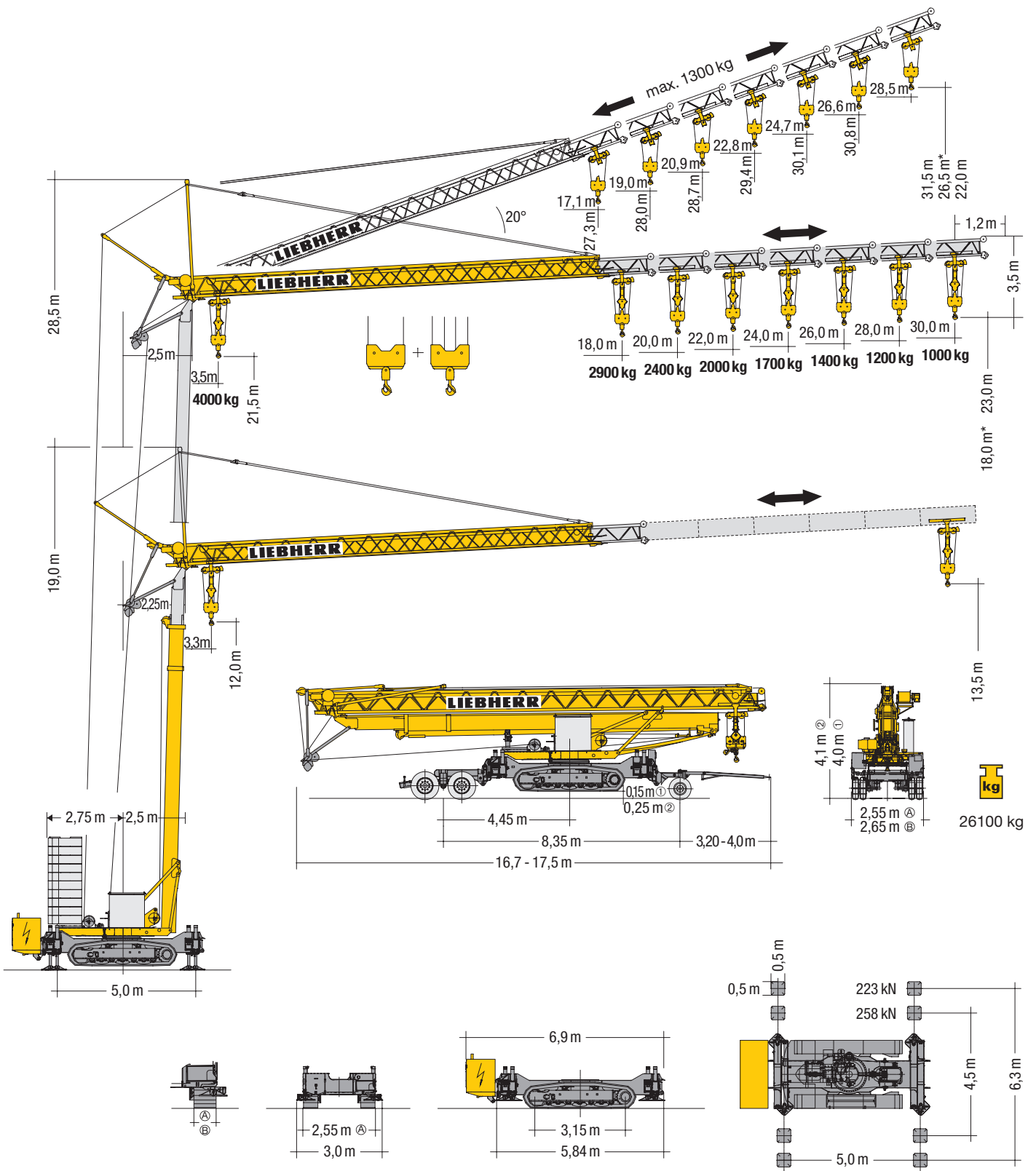

Gewicht Weight / Poids / Peso / Pesos / Macca

	17500 kg		ca. 23000 kg
--	----------	--	--------------

* siehe Betriebsanleitung. / see instruction manual.
voir manuel de service. / vedi manuale d'istruzione.
ver manual de instrucción. / ver manual de instruções.
см. инструкцию по эксплуатации.



Kettenbreite / Chain width / Largeur de chaîne
Larghezza cingoli / Anchura de cadena
Comprimento dos rastros
Ширина гусеницы ④ = 0,5 m / ③ = 0,6 m

① 0,15 m \triangleq 4,0 m
② 0,25 m \triangleq 4,1 m

Ausladung und Tragfähigkeit

Radius and capacity / Portée et charge / Sbraccio e portata
Alcances y cargas / Alcance e capacidade de carga / Вылет и грузоподъемность

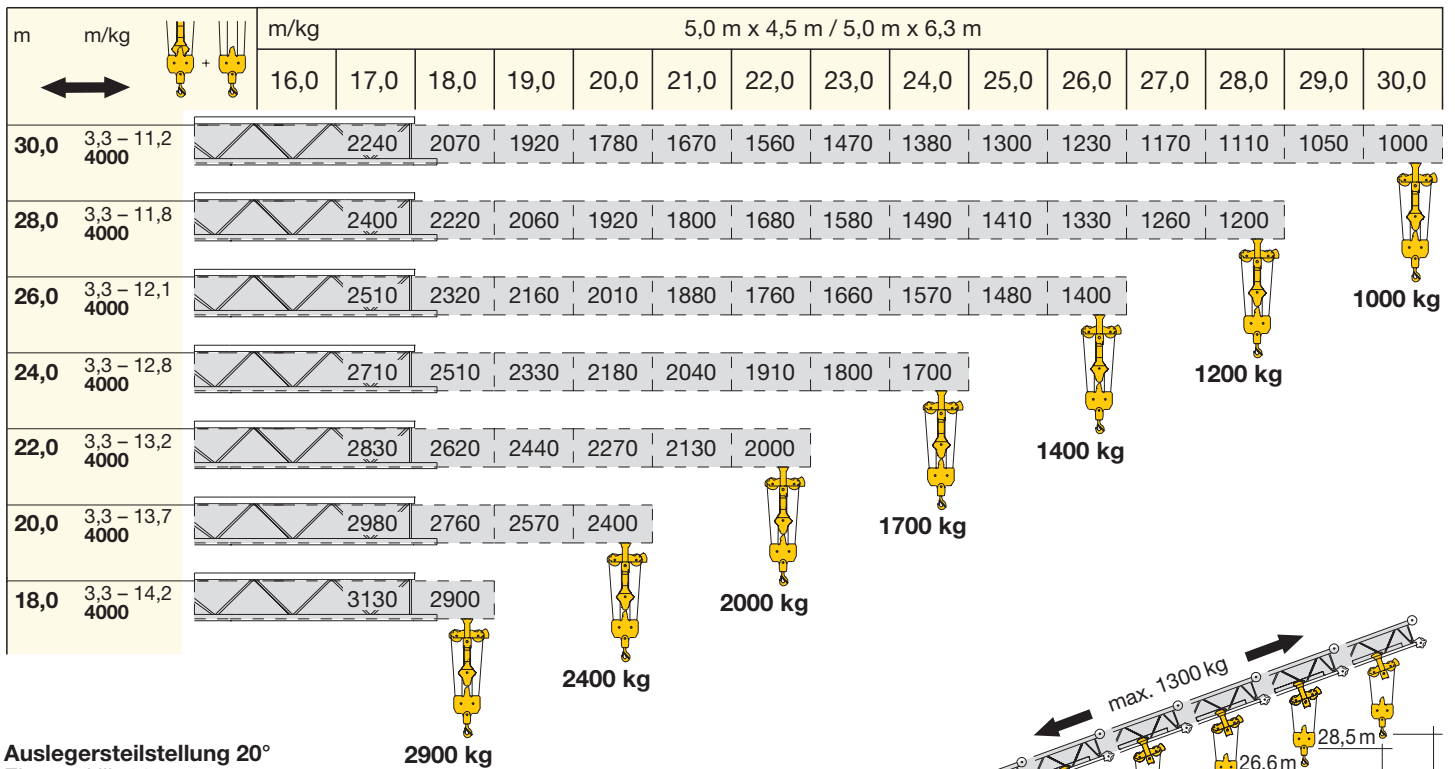
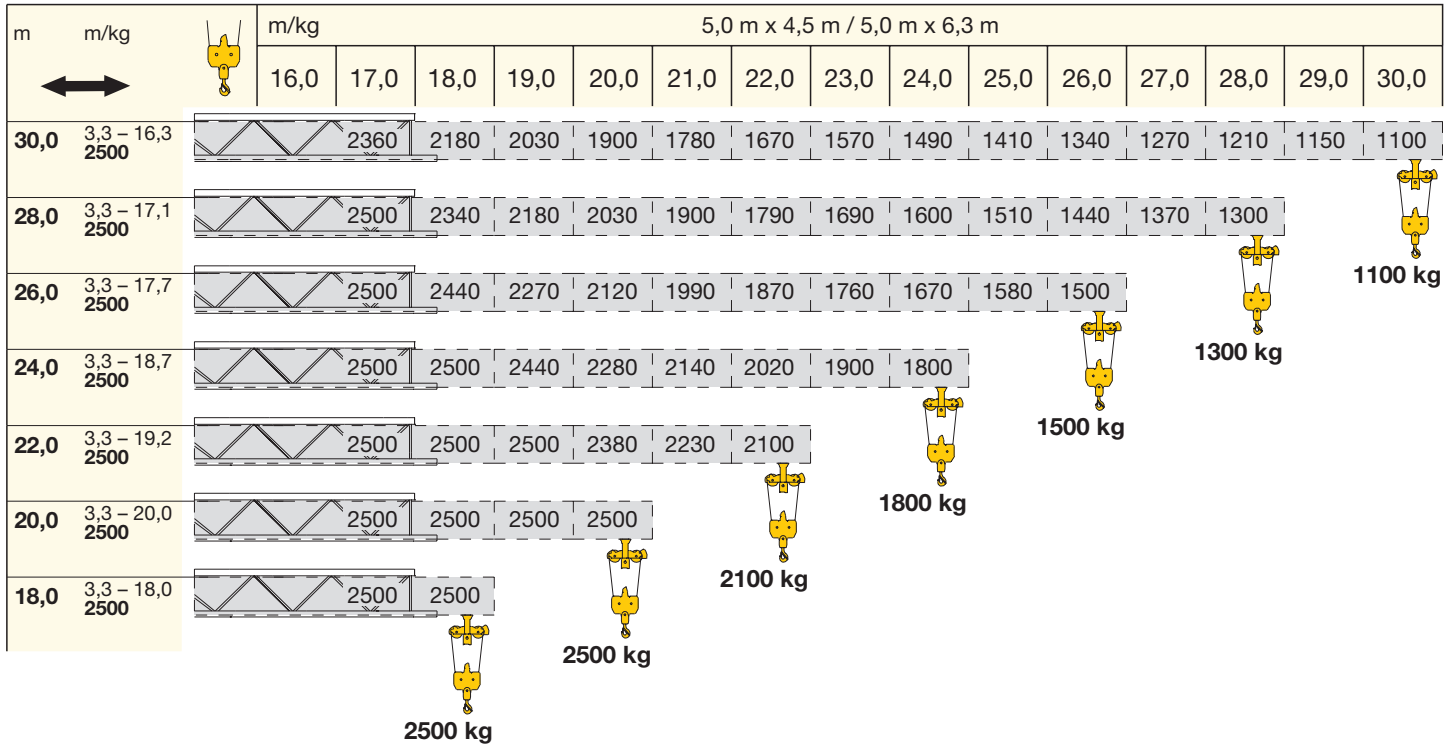

Auslegersteilstellung 20°

Elevated jib 20°
Flèche inclinée 20°
Braccio inclinato a 20°
Pluma inclinada 20°
Lança inclinada 20°
Положение стрелы под углом 20°

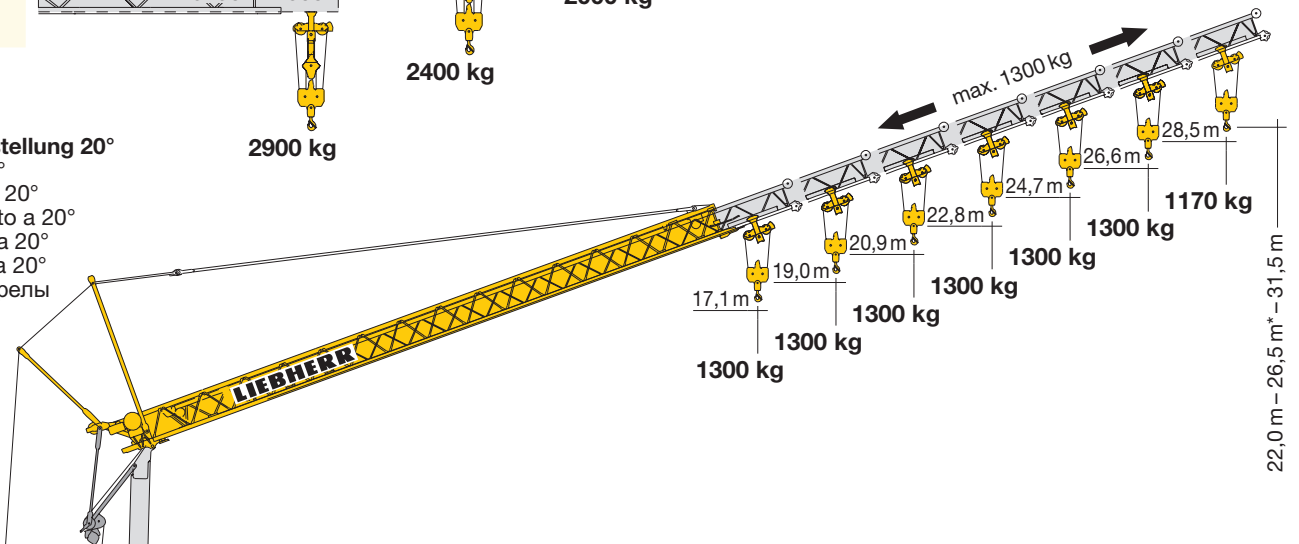

Geländegängigkeit

Off-road capability / Aptitude en tout terrain / Idoneità al fuoristrada / Aptitud de marcha sobre toda clase de terrenos / Capacidade de funcionamento sobre todo o tipo de terrenos / Повышенная проходимость

	30 %	15 %	8 %
	15 %	10 %	3 %
	14 N/cm ² Ⓐ 12 N/cm ² Ⓑ	25 N/cm ² Ⓐ 21 N/cm ² Ⓑ	25 N/cm ² Ⓐ 21 N/cm ² Ⓑ
V_{max}	25 m/min	10 m/min	10 m/min

Antriebe

Driving units / Mécanismes d'entraînement / Meccanismi / Mecanismos / Mecanismos / Приводы

	U/min. 0 ↔ 0,8 sl./min tr./min	3,0 kW EDC
	20,0 / 40,0 m/min	2,6 / 3,5 kW
	10,0 m/min	2,6 kW
	4,0 m/min	5,0 kW

	Stufe / Step / Cran / Marcia Velocidad / Velocidade Передача	kg	m/min
11,0 kW KL 	1	2500	5,0
	2	2500	20,0
	3	1300	40,0
11,0 kW FU 	1	2000 4000	5,0 2,5
	2	2000 4000	20,0 10,0
	3	1300 2600	40,0 20,0
11,0 kW FU 	1	2500	4,0
	2	2500	20,0
	3	1300	38,0
	4	1000	50,0
	1	2000 4000	4,0 2,0
	2	2000 4000	20,0 10,0
	3	1300 2600	38,0 19,0
	4	1000 2000	50,0 25,0





	400 V	Hz	kVA
50,0 m	4 x 6 mm ² KL	50	22,0 KL
77,0 m	4 x 6 mm ² FU		20,0 FU

	Hz	kVA
400 V / 3 ~	50	22

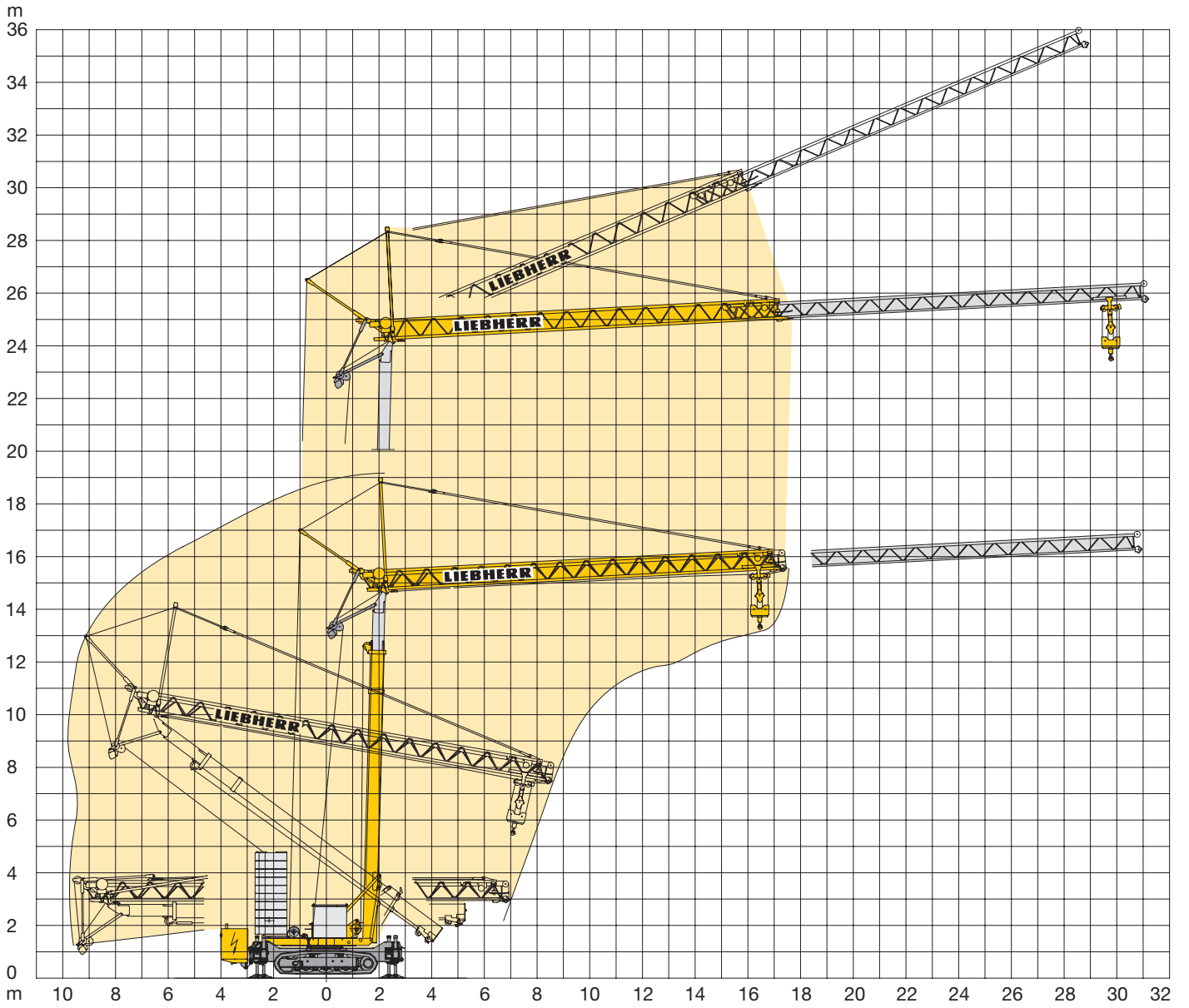
BGL 	C.0.08.0031		95 L _{WA} 70 dB(A)

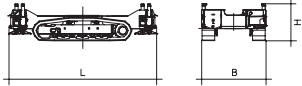
	Hz	kVA
400 V / 3 ~	50	66,0 (97 A)
230 V	50	20,0 (97 A)

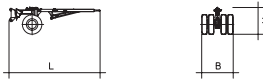

Pos. Item Rep. Voce Pos. Ref. Поз.	Anz. Qty. Qte. Qta. Cant. Cant. Кол-во			L (m)	B (m)	H (m)	kg
1	1	Raupenunterwagen / Crawler undercarriage Châssis à chenilles / Carro cingolato Carro sobre raíles / Carro de lagarta Опорная рама на гусеничном шасси		5,835	2,55 (A) 2,65 (B)	1,46	12000
2	1	Stromgenerator mit Konsole / Current generator with bracket Générateur de courant avec semelle Generatore di corrente con supporto / Generator de corrente de consola / Gerador de corrente de consola / Генераторный агрегат с кронштейном		72 kVA	2,49	1,03	1350
3	1	Transportachse vorne Tra 100 KY 6A / Road transport axle front Essieux de transport avant / Asse di trasporto anteriore / Eje delantero para transporte / Eixo de transporte dianteiro / Транспортировочная ось, передняя		3,63 - 4,13	1,42	1,10	920
4	1	Transportachse hinten Tra 204 GZ1 / Road transport axle behind Essieux de transport arrière / Asse di trasporto posteriore / Eje trasero para transporte / Eixo de transporte traseiro / Транспортировочная ось, задняя		2,50	2,50	1,00	2000

Konstruktionsänderungen vorbehalten! / Subject to alterations! / Sous réserves de modifications! / Reservato il diritto di modifiche strutturali!
¡Sujeto a modificaciones! / Salvo modificação da construação! / Права на внесение конструкторских изменений сохраняются!

Sämtliche Angaben erfolgen ohne Gewähr. / This information is supplied without liability. / Ces renseignements sont sans garantie. / Tutte le indicazioni fornite senza garanzia. / Declinamos toda responsabilidad derivada de la información proporcionada. / Declinamos qualquer responsabilidade quanto à informação fornecida. / Все данные указаны без обязательств.

120 P – 4637 H1 B3 DIN 15018 • BGL C.0.08.0031 / FEM (Section1) Krangruppe A3 und OENORM T3 • 03.07 / 6 Printed in Germany.