

Function

The thermostatic controls have the function of keeping the ambient temperature constant in the places where they are installed, keeping it at the previously set value.

The thermostatic head 1100 is equipped with a liquid sensor.



Dimensions

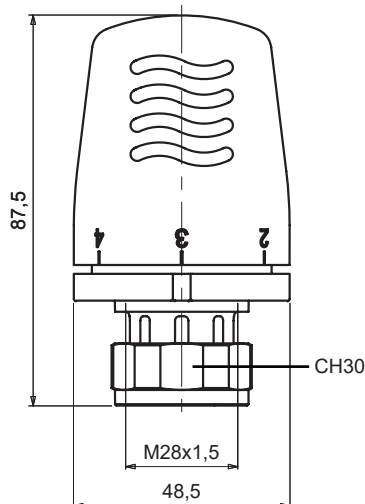

Product Range

SERIES	CODE	CONNECTION
1100	821100AC20	28x1,5

Technical Features

Adjustment range:		* to 5
Temperature setting range:		7 to 28°C
Saving state (position):		20°C (3)
Minimum set point (freezing protection position):	min ts	7°C (*)
Maximum set point (position):	max ts	28°C (5)
Maximum operating pressure:	PN	1000 KPa
Maximum differential pressure:	Δp	100 KPa
Nominal flow rate - angle and straight valve:	qm N	190 Kg/h
Response time:	Z	20 min
Authority:	a	0,9
Hysteresis:	C	0,19 K
Differential pressure influence:	D	0,25 K
Water temperature influence:	W	0,7 K
Control Accuracy	CA	0,2 K
Maximum operating temperature:		110°C
Maximum storage temperature:		50°C

* Declared values are referred to thermostatic head installed on ICMA valve bodies 774/775 1/2", 774+940/775+940 1/2", 974/975 1/2".

Temperature Adjustment

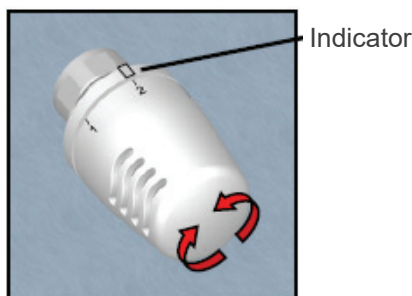

ADJUSTMENT RANGE						
0°C	7°C	12°C	16°C	20°C	24°C	28°C
0	❄	1	2	3	4	5

Installation

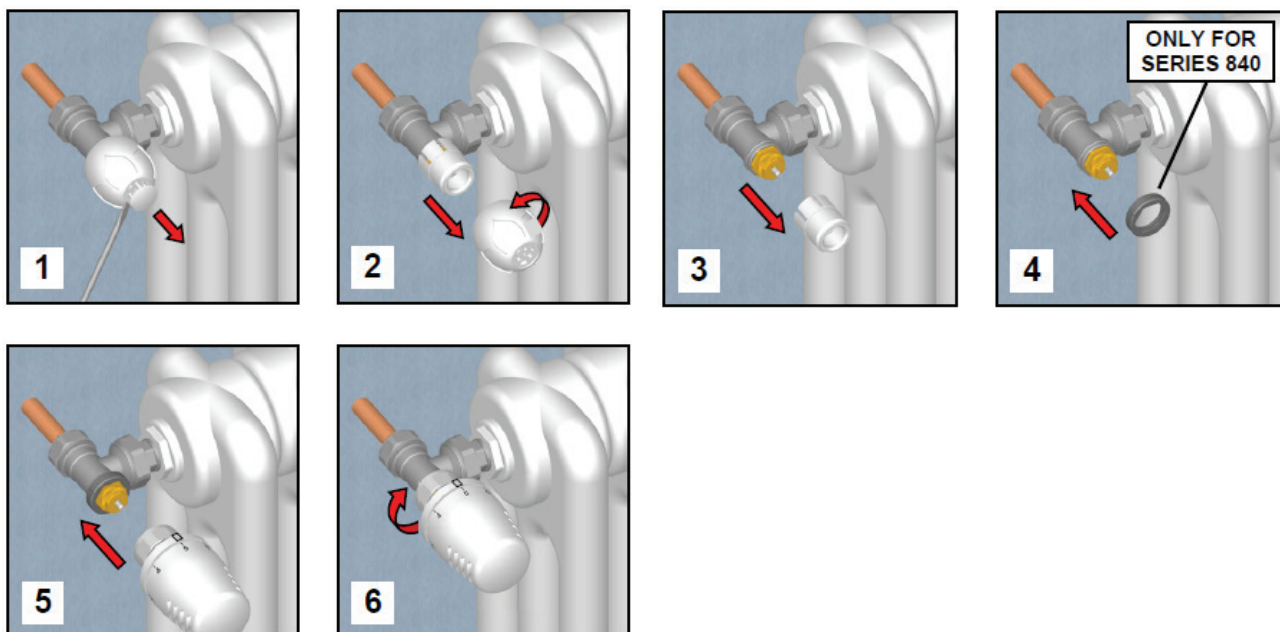

Temperature Block

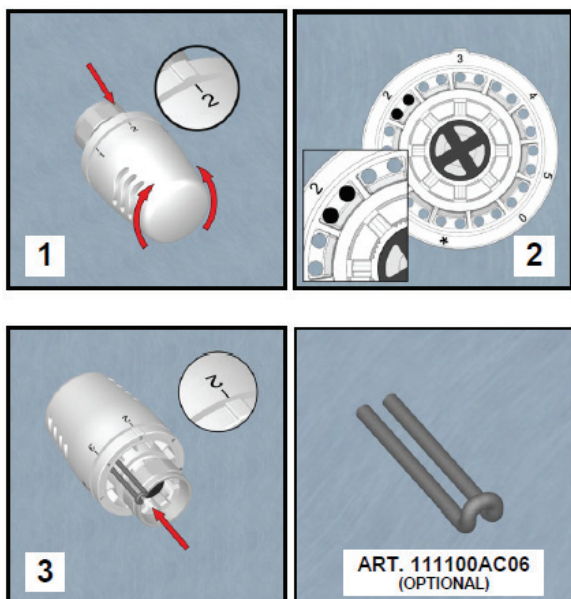

Temperature Limitation

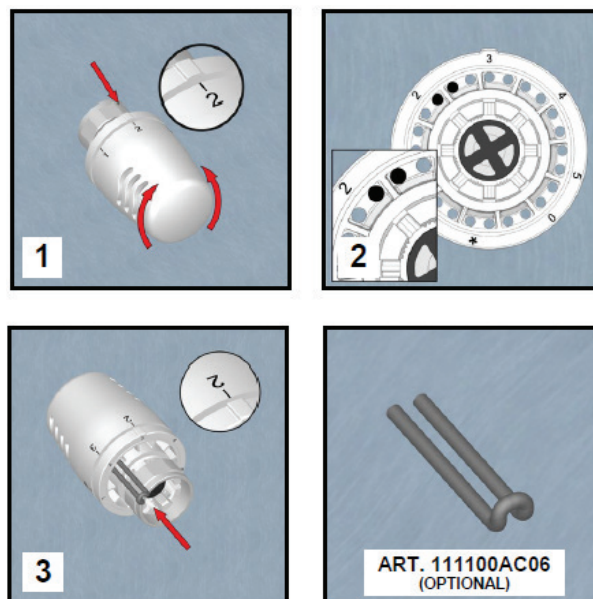

CAUTION



During the summer to avoid excessive loads on the seal of the thermostatic head, with the consequent risk of jamming and blocking, it is advisable to position the knob in the maximum opening position.

Hydraulical Features

Thermostatic Valve 774 - 1/2"
PRESSURE DROP DIAGRAM

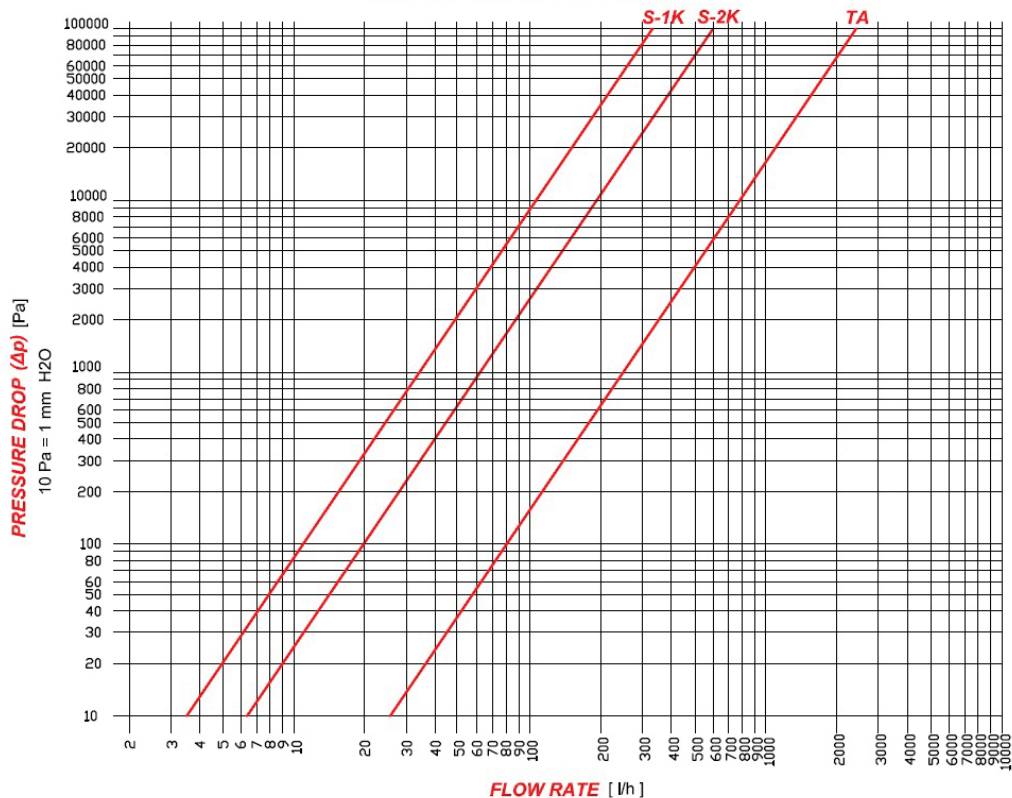

	Kv [m ³ /h]
TA	2,21
S-2K	0,60
S-1K	0,33

Thermostatic Valve 774 - 3/4"
PRESSURE DROP DIAGRAM

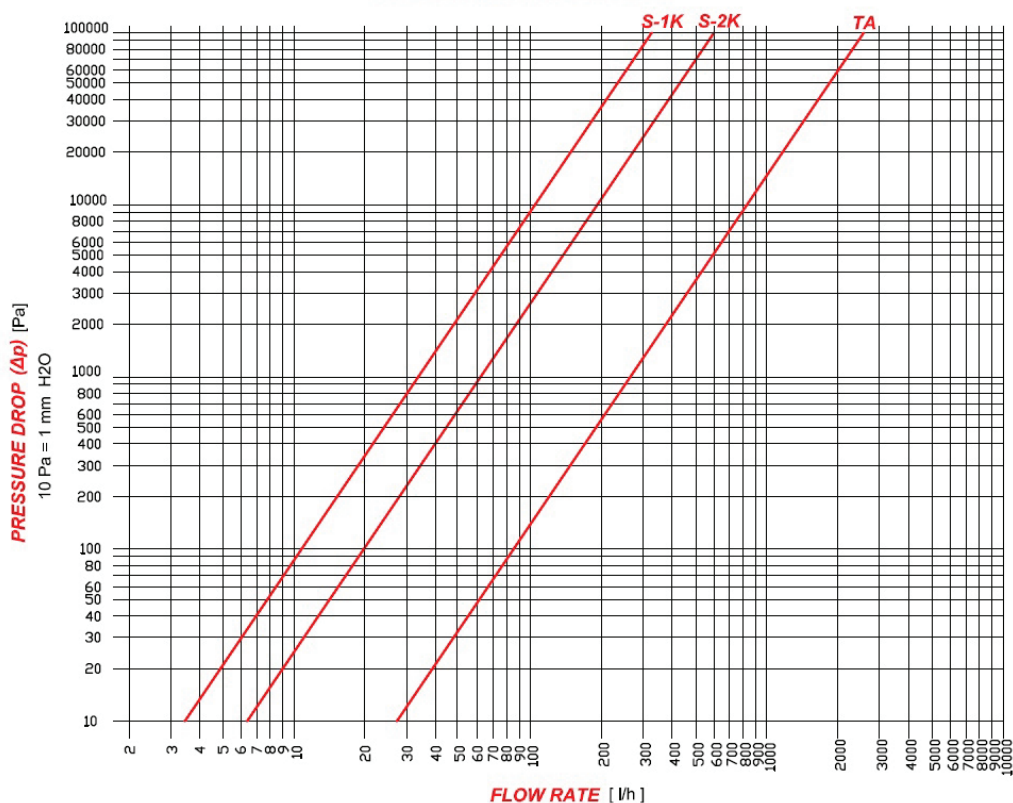

	Kv [m ³ /h]
TA	2,53
S-2K	0,60
S-1K	0,33